

USE AND MAINTENANCE MANUAL

TS52E SIDE SHIFT FLAIL MOWER (FUNNY TOP 132)



PREFACE

This manual is an integral part of the machine.

It must always accompany the machine and be kept within reach of the operator.
The enclosures mentioned are an integral part of this manual.

The purpose of this manual.

This manual gives information for the correct and safe use of the machine.
The owner must read this manual carefully before work with the machine.

Responsibility of the owner

The owner is responsible for accidents or damages caused to people or things due to negligence in following the instructions in this manual.

Assistance in using this manual

Explanations: contact the dealer.

Request for additional copies of the manual: in case of loss or wear and tear, or in case one wants the manual in a different language, the customer should ask the dealer or manufacturer.

Pay attention to the warning signals



<Danger>: indicates a situation that is potentially dangerous which, if not avoided, will cause death or serious damage.



<Warning>: indicates a situation that is potentially dangerous which, if not avoided, will cause death or serious damage.



<Caution>: indicates a situation that is potentially dangerous which, if not avoided, can cause minor to moderate damage, or it indicates to be careful about an unsafe procedure.

<Important> : indicates instructions that must be followed precisely in order to avoid damage to the product, process or environment.

<Note>: indicates supplementary information.

| |
|--------------------|
| DESCRIPTION |
|--------------------|

FUNCTION OF USE

The machine according to the different tools can makes different functions like cut grass, cut up poles exc. The use of a technical constructive concept trended to the search of high performances, reduction of trebles and durability, improves the power/consumption ratio of the tractor thanks to the elasticity of the machine frame, to the tools shape, to the perfect rotor balancing and to many original technical solutions.

PERFORMANCES

The machine is connected to the tractor with a three points hitch that gives the motion of translation and with a PTO shaft connected with the tractor PTO that gives the motion of rotation to the hoes shaft. The working width is fix and it's determined from the choice of the machine type. The working depth is adjustable. The working zone is adjustable respect to tractor axis. The rear roll adjusts the cutting height and provides to tread the cut material.

PERFORMANCES LIMIT

- ❑ Speeds greater than the maximum can compromise the condition of the machine, the quality of the work and the safety of the operator.
- ❑ Maximum power applicable to the gear box: from 9 to 20 Kw \pm 5% with 540 r.p.m. Superior power to which is indicated can damage irreparably the transmission gear box; especially during heavy works.

STANDARD EQUIPMENTS

- **Standard PTO shaft.**
- **Free wheel device inside gear box.**
- **Rear roll.**
- **Blade tools**
- **Aluminum gear box**

VARIANTS & OPTIONS

- **Spatula tools**
- **Hammer tools**
- **Iron casting gear box**
- **Rear roll extension**
- **Kit Quick hitch**

TECHNICAL SPECIFICATIONS

CHARACTERISTICS PER MODEL

| Model | Typo | Version | Power | | Working width | | Weight | | Dimensions A x B x H | Tools nr | Rotor RPM |
|--------------|------|---------|-------|------|---------------|------|--------|-----------|-------------------------|-------------|--------------|
| | | | Hp | Kw | cm | Inch | kg | lbs | Cm | n° | g/min |
| FUNNY TOP | 80 | S | 12-28 | 9-20 | 80 | 32 | 123 | 271 | 94x60x60 | 12 | 2410 |
| | 80 | GS | 12-28 | 9-20 | 80 | 32 | 124 | 273 | 94x60x60 | 12 | 2410 |
| | 93 | S | 12-28 | 9-20 | 93 | 36 | 132 | 291 | 107x60x60 | 16 | 2410 |
| | 93 | GS | 12-28 | 9-20 | 93 | 36 | 133 | 293 | 107x60x60 | 16 | 2410 |
| | 106 | S | 12-28 | 9-20 | 106 | 42 | 136 | 300 | 120x60x60 | 16 | 2410 |
| | 106 | GS | 12-28 | 9-20 | 106 | 42 | 137 | 302 | 120x60x60 | 16 | 2410 |
| | 119 | S | 12-28 | 9-20 | 119 | 47 | 143 | 315 | 133x60x60 | 20 | 2410 |
| | 119 | GS | 12-28 | 9-20 | 119 | 47 | 144 | 317 | 133x60x60 | 20 | 2410 |
| | 132 | S | 12-28 | 9-20 | 132 | 52 | 150 | 332 | 146x60x60 | 20 | 2410 |
| | 132 | GS | 12-28 | 9-20 | 132 | 52 | 151 | 333 | 146x60x60 | 20 | 2410 |
| | 158 | S | 12-28 | 9-20 | 158 | 62 | 177 | 390 | 172x60x60 | 24 | 2410 |
| 158 | GS | 12-28 | 9-20 | 158 | 62 | 178 | 392 | 172x60x60 | 24 | 2410 | |
| FUNNY TOP | 80 | C | 12-28 | 9-20 | 80 | 32 | 123 | 271 | 94x60x60 | 24 | 2410 |
| | 80 | GC | 12-28 | 9-20 | 80 | 32 | 124 | 273 | 94x60x60 | 24 | 2410 |
| | 93 | C | 12-28 | 9-20 | 93 | 36 | 132 | 291 | 107x60x60 | 32 | 2410 |
| | 93 | GC | 12-28 | 9-20 | 93 | 36 | 133 | 293 | 107x60x60 | 32 | 2410 |
| | 106 | C | 12-28 | 9-20 | 106 | 42 | 136 | 300 | 120x60x60 | 32 | 2410 |
| | 106 | GC | 12-28 | 9-20 | 106 | 42 | 137 | 302 | 120x60x60 | 32 | 2410 |
| | 119 | S | 12-28 | 9-20 | 119 | 47 | 143 | 315 | 133x60x60 | 40 | 2410 |
| | 119 | GS | 12-28 | 9-20 | 119 | 47 | 144 | 317 | 133x60x60 | 40 | 2410 |
| | 132 | C | 12-28 | 9-20 | 132 | 52 | 150 | 332 | 146x60x60 | 40 | 2410 |
| | 132 | GC | 12-28 | 9-20 | 132 | 52 | 151 | 333 | 146x60x60 | 40 | 2410 |
| | 158 | C | 12-28 | 9-20 | 158 | 62 | 177 | 390 | 172x60x60 | 48 | 2410 |
| 158 | GC | 12-28 | 9-20 | 158 | 62 | 178 | 392 | 172x60x60 | 48 | 2410 | |
| FUNNY TOP | 80 | M | 12-28 | 9-20 | 80 | 32 | 123 | 271 | 94x60x60 | 12 | 2410 |
| | 80 | GM | 12-28 | 9-20 | 80 | 32 | 124 | 273 | 94x60x60 | 12 | 2410 |
| | 93 | M | 12-28 | 9-20 | 93 | 36 | 132 | 291 | 107x60x60 | 16 | 2410 |
| | 93 | GM | 12-28 | 9-20 | 93 | 36 | 133 | 293 | 107x60x60 | 16 | 2410 |
| | 106 | M | 12-28 | 9-20 | 106 | 42 | 136 | 300 | 120x60x60 | 16 | 2410 |
| | 106 | GM | 12-28 | 9-20 | 106 | 42 | 137 | 302 | 120x60x60 | 16 | 2410 |
| | 119 | S | 12-28 | 9-20 | 119 | 47 | 143 | 315 | 133x60x60 | 20 | 2410 |
| | 119 | GS | 12-28 | 9-20 | 119 | 47 | 144 | 317 | 133x60x60 | 20 | 2410 |
| | 132 | M | 12-28 | 9-20 | 132 | 52 | 150 | 332 | 146x60x60 | 20 | 2410 |
| | 132 | GM | 12-28 | 9-20 | 132 | 52 | 151 | 333 | 146x60x60 | 20 | 2410 |
| | 158 | M | 12-28 | 9-20 | 158 | 62 | 177 | 390 | 172x60x60 | 24 | 2410 |
| 158 | GM | 12-28 | 9-20 | 158 | 62 | 178 | 392 | 172x60x60 | 24 | 2410 | |

Version:

- C = Blade, aluminum gear box**
- S = Spatula, aluminum gear box**
- M= Hamme, aluminum gear box r**
- GC = Blade, iron casting gear box**
- GS = Spatula, iron casting gear box**
- GM= Hammer, iron casting gear box**

SAFETY INFORMATIONS

GENERAL PRESCRIPTIONS

- ❑ Only work in daylight.
- ❑ To prevent damage due to lunch of objects or parts of blades, before to start job be sure that any persons or animals should be in the radius of 50 meters from the machine.
- ❑ Wear long pants and heavy shoes.
- ❑ The protections are integral part of the machine: always work with the protections.
- ❑ Pay attention to the soil: make sure that are not stones, sticks, iron wires, etc...
- ❑ Pay attention using the machine on slopes: proceed to the maximum slope and never work in slanting direction.
- ❑ Before leaving the driver's seat, turn off the engine and disengage the transmission engine-shaft.
- ❑ Check immediately the machine if it touches foreign objects.
- ❑ Check immediately the machine if there are unusual strong vibrations.
- ❑ Change quickly defective parts.

❑ **CAUTION – WARNING:**

Gear box has inside a free wheel device, after P.T.O. disconnection rotor turns for at least 30 seconds, before approach the tools be sure that the rotor is stopped.

❑ **WARNING:**

To prevent damage to the PTO shaft and to the gear box, don't start the machine roughly.

SAFETY RESTRICTIONS

Children and people who are not familiar with these instructions must not be permitted to use the machine. Local regulations can restrict the use of the machine in accordance to the age.

RUNNING IN

A new machine needs a running in. At the first use connect the machine to the tractor, connect the PTO shaft, pull down the machine at 15 centimeters from ground then start the P.T.O. and gradually bring it to 540 r.p.m... Run the machine for about 15 minutes. A whistle in the supports zone it is normal and it's due to the arrangement of the support protection, it will disappear in a few times. After first 30 minutes of work check belts tension.

SAFETY SIGNS ON THE MACHINE

In this section, the safety signs on the machine are reproduced and explained.



1. Read the operator manual.
2. Disconnect the tractor key before maintenance and repair operations.
3. Stay at safety distance from blades when machine is moving.
1. Danger of flying objects. Stay at safety distance.
4. Stay at safety distance from blades when machine is moving.
5. Stay at safety distance from blades when machine is moving.

The safety signs on the machine must always be legible.

In case of damage, the labels of the signs must be substituted.

In the case of the substitution of machine parts that have safety signs, the signs must be replaced.

Supplying of new safety labels and the application procedure

Contact your dealer to receive new safety labels with instructions for application.

CARDAN SHAFT LENGTH CHECKING

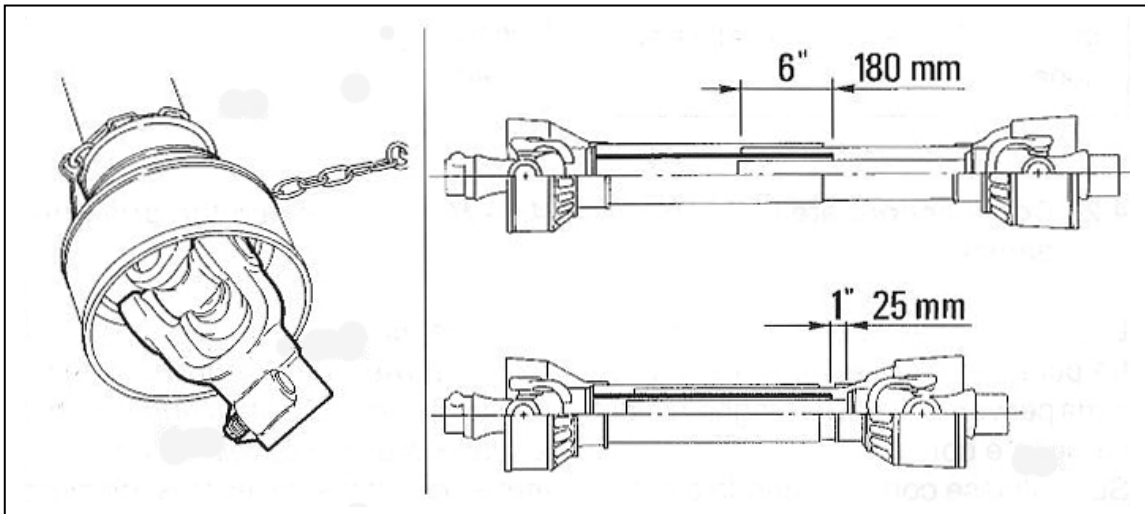

1. After having linked up the machine to the third point, please check it is placed in a horizontal and central position in relation to the tractor using the adjustment devices.
2. Place the PTO shaft between the tractor's PTO and the machine's PTO.
3. Check the length of the PTO shaft.
4. The length of the PTO shaft is correct if in the working position the minimum length of the coupling between the inner tube and the outer tube is not less than 180 mm and if, at the same time, in the condition of minimum extension, the PTO shaft still can make a movement of 25 mm.
5. If the minimum coupling length is less than 180 mm, it means that the PTO shaft is too short and you will need to replace it with a longer one.
6. If in condition of minimum extension the PTO can run less than 25 mm, it is too long and it must be shortened.
7. **WARNING:** shortening a PTO shaft is quite complicated. Always read the instructions contained in the following chapter before starting this delicate procedure not to damage the PTO shaft.

HOW TO SHORTEN THE CARDAN SHAFT

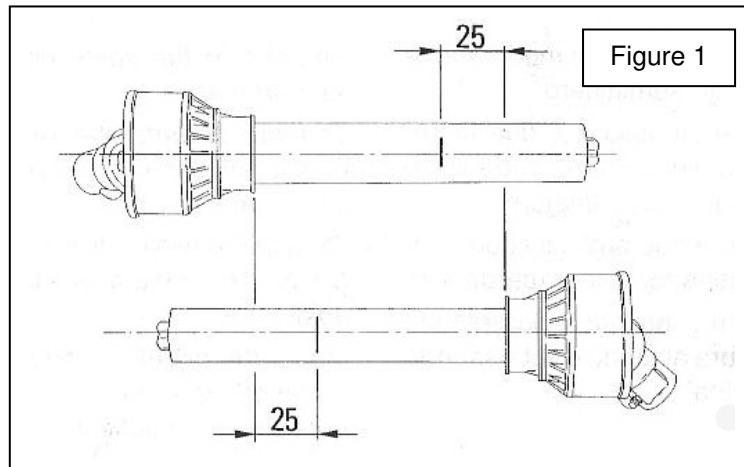

1. Move the machine as close as possible to the tractor, by using an hydraulic lift.
2. Once in this position, stop the hydraulic lift and switch the engine off.
3. Separate the two parts of the PTO shaft.
4. Insert the "female" PTO shaft (that is to say the larger-diameter tube) in the tractor's PTO.
5. Insert the "male" PTO shaft (that is to say the smaller-diameter tube) in the machine's PTO.
6. Place each part of the PTO shaft parallel to the other. Then, use a permanent marker to highlight the cutting point as shown in the figure "1".

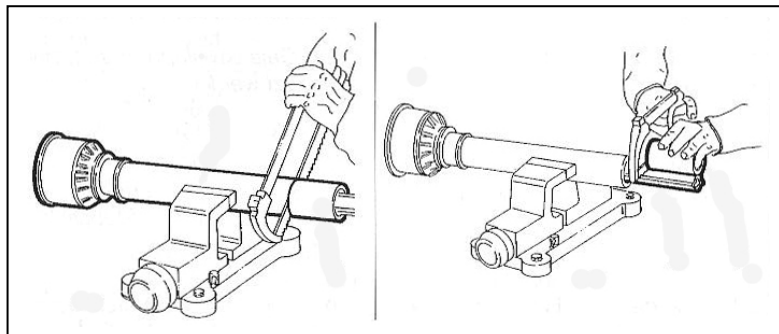

1. Use a bow saw to cut the plastic tube on the marker line that you had already drawn on one of the PTO shaft parts.
2. Align the part of the tube that you have already cut at the bottom of and cut it.
3. Repeat the same operations on the second part of the PTO shaft.
4. Use a file to bevel the extremities of the tubes.
5. Clean and grease the two metallic tubes and insert the first part of the PTO shaft inside the other.
6. Set up the PTO shaft between the tractor and the machine and check its length another time.

INSTRUCTIONS FOR USE

1. BEFORE BEGINNING WORK

- a) Hook the machine to the tractor, operate as follows:
 1. Remove the safety pins from the two lower connection points of the machine.
 2. Plug in the raising tractor beams into the lower connection points of the machine and lock with the safety pins.
 3. Connect through tie-rod the third hitch point of the tractor with the third point of the machine (the connection triangle vertex), insert the pin and lock with safety pin.
- b) With the machine raised, go to work area.
- c) Connect the tractor PTO with machine PTO.
- d) Check that PTO chain is locked to prevent the protection sheet of PTO rotating.
- e) Adjust the cutting height as follow:
 1. Pull down the machine since the rear roll touches the ground.
 2. Extend the III^o point tie rod to increase the cutting height, shorten it to decrease.
 3. After the regulation, lock the safety not of the tie rod.

2. TO BEGINNING WORK

- a) Make sure that there is no one within a radius of 50 meters (164 ft) around the implement.
- b) Insert the PTO and increase the rotation speed gradually to its normal speed.
- c) Lower the implement until the rear roller touches the ground.
- d) Start working.

3. AT THE END OF CUTTING OPERATION

- a) Stop the tractor and wait at least 30 seconds that the rotor is completely stopped.
- b) Raise the machine until the hoes goes out from ground.
- c) Disconnect PTO power.
- d) Disconnect tractor PTO from machine PTO.
- e) Raise completely the machine.

| |
|---------------------------------|
| MAINTENANCE INSTRUCTIONS |
|---------------------------------|

On diagram "A" the maintenances are indicated with their terms to effect on the machine.
 Not follow the scheduled terms can compromise the functionality of the machine and in this case the warranty is not applicable.

DIAGRAM "A" SCHEDULED MAINTENANCE

| | FIRST START | AFTER 10 H. | EACH 30 H. | EACH 500 H. | END SEASON | START WORK | END WORK |
|-----------------|--------------------|--------------------|-------------------|--------------------|----------------------|-------------------|-----------------|
| MACHINE | Greasing | | Greasing | | Cleaning Greasing | | Cleaning |
| GEAR BOX | Oil level | Oil level | Oil level | Change oil | | | |
| SCREW | | Screw | Screw | | | | |
| TOOLS | | | Check | | Check | Check | Check |
| BELTS | | Check | | Replacement | | | |

1. GREASING

At the scheduled time on diagram "A", grease points "B" "C", "D", "E", "F", "G".

Greasing point is equipped with greaser HYDRAULIC TYPE MODEL "A" UNI 7663.

To greasing use only MULTIFUNCTIONAL GREASE LITHIUM BASED Type NLGI 2.

2. OIL CHECK - OIL REPLACEMENT IN ALUMINUM GEAR BOX

At the scheduled time on diagram "A", check or replace oil into gear box.

To fill oil use only OIL SAE 90.

Gear box capacity: 0,5 L

a) To check oil level into the gear box, operate as follow:

1. With the machine on level unscrew plug "A" then check that oil touches on lower hole rim.
2. If the level is ok, screw plug "A".
3. If the level is slow, refill.
4. When the level is ok, screw plug "A".

b) To change oil into the gear box, operate as follow:

1. Unscrew plug "A" and take away oil using a suitable little pump.
2. Fill oil from plug "A".
3. When level is ok, screw plug "A".

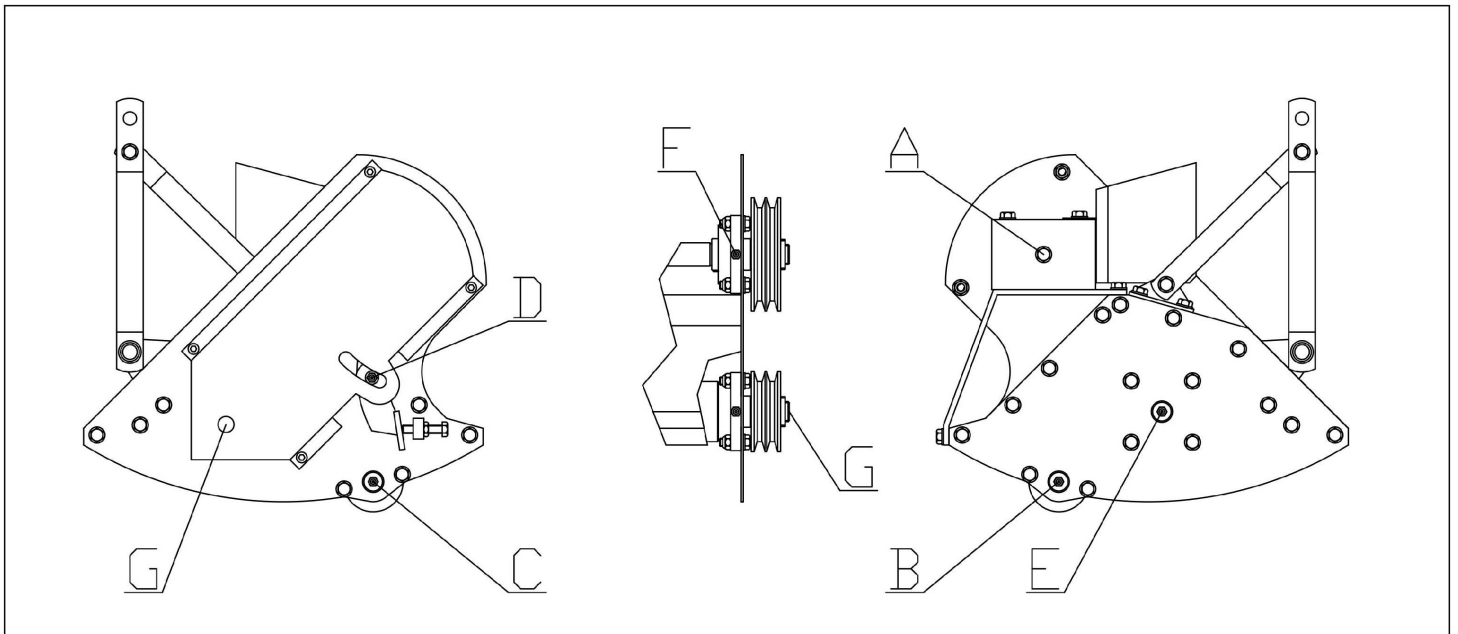

3. OIL CHECK - OIL REPLACEMENT IN IRON CASTING GEAR BOX

At the scheduled time on diagram "A", check or replace oil into gear box.
To fill oil use only OIL SAE 90.
Gear box capacity: 0,8 L

a) To check oil level into the gear box, operate as follow:

1. With the machine on level, remove the safety plastic cover from the front side of the gear box, unscrew plug "TL" and check that oil touches on lower hole rim.
2. If the level is ok, screw plug "TL".
3. If the level is low, unscrew plug "TR" and refill.
4. When the level is ok, screw plug "TL" and "TR".

b) To change oil into the gear box, operate as follow:

1. Remove the safety plastic cover from the front side of the gear box, unscrew plugs "TL", "TR" and the discharge plug "TS", wait until all oil has come out.
2. Screw the discharge plug "TS" then fill oil from plug "TR".
3. When level is ok, screw plugs "TL" and "TR" and assemble the safety plastic cover.

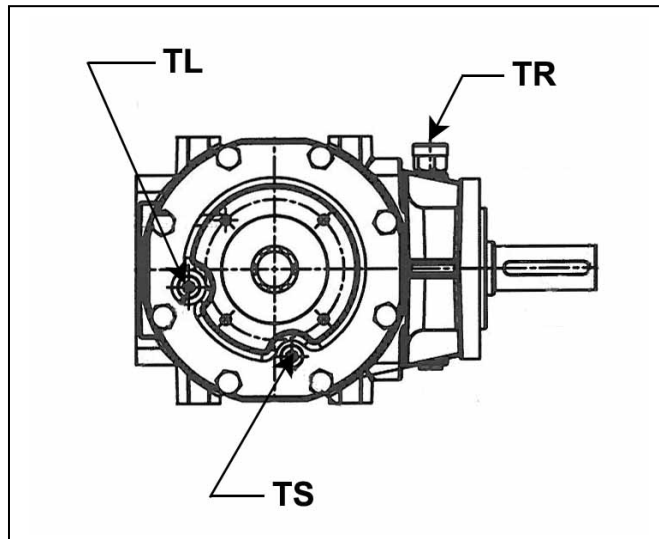

4. TOOLS REPLACEMENT

a) To change tools, operate as follow :

1. Unscrew the nut then take out the screw "B".
2. Take out tools "A" with bushes.
3. Assemble the new tool.
4. Fit the screw "B" then screw the nut.
5. **ATTENTION: all tools must be of the same type.**
6. **ATTENTION: changing type of tools you must balance again the rotor.**

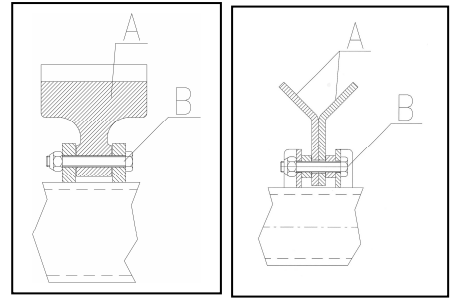

5. BELTS ADJUSTING AND REPLACEMENT

a) To adjust the tension of the transmission belts, operate as follow:

1. Disassemble safety protection "E" unscrewing the four screws "D".
2. Loosen the lock nut "A" of the belt tensioner and screw the screw "B" in or out to increase or decrease the tension of the belts. The belt tension is correct when the belts flex about 1/8" when pushing them on the side opposite of the belt tensioner.
3. After operation screw the lock nut "A" then assemble the safety protection "E".

b) To change the transmission belts, operate as follow:

1. Disassemble safety protection "E" unscrewing the four screws "D".
2. Unscrew the lock nut "A" then full unscrew the screw "B"
3. Remove the old belts "E", to prevent adjusting problems you must replace both, and then assemble the new referring to the characteristics in the SPARE PART LIST.
4. Make operations "2" and "3" point "a".
5. **ATTENTION: after first 30 minutes of work check belts tension.**

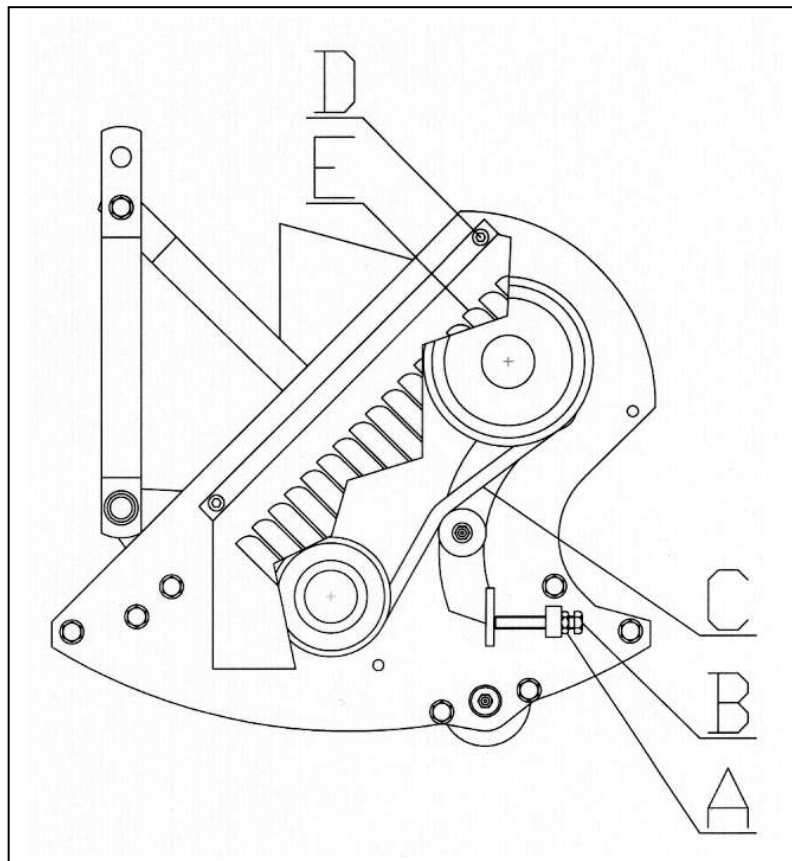

6. QUICK HITCH KIT ASSEMBLY

The machine is shipped with the standard hitch suitable for tractors with category I 3-point hydraulic lift, a "quick hitch kit" is supplied with the machine to make the hitch suitable for tractors equipped with a "Quick Attaching Coupler".

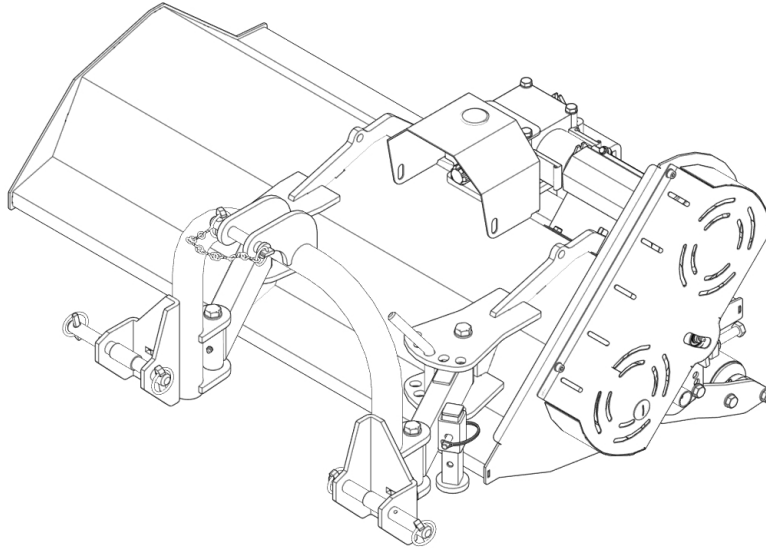

Standard Attachment

To mount the quick hitch kit, proceed as follows:

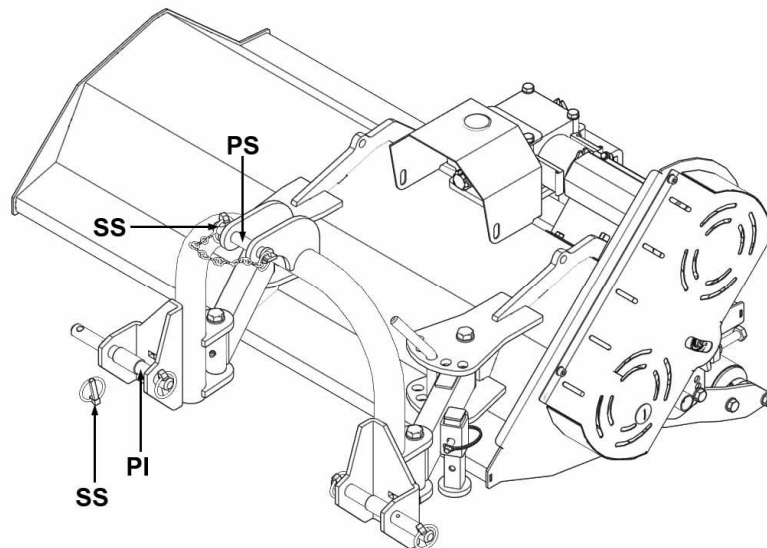

1. Remove the SS safety pin from the lower "PI" pins,
2. Remove the safety pin "SS" from the upper pin "PS" and slide it out of its seat.

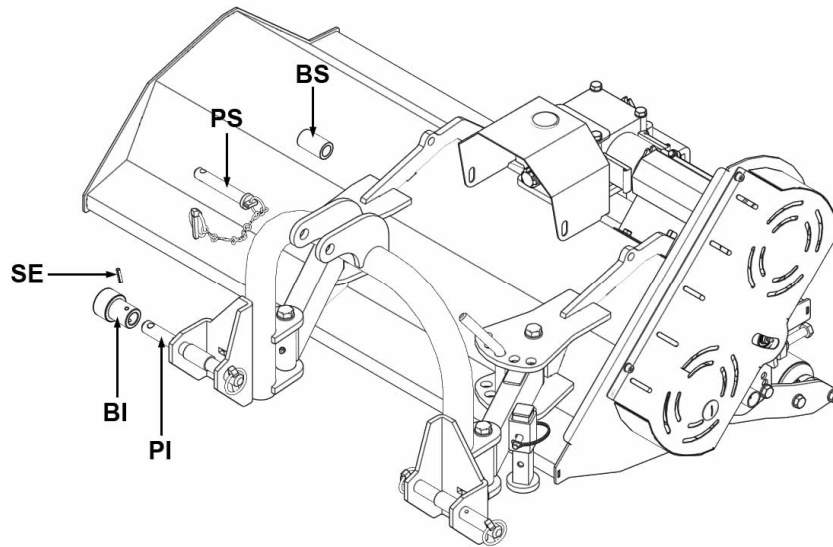

1. Insert the bushing "BI" onto the lower right pin "PI" and then lock it with the spring pin "SE".
2. Repeat step 1 with the left lower pin "PI".
3. Insert the bushing "BS" into the upper connection of the III° point, then insert the pin "PS" and lock it with the safety pin "SS".

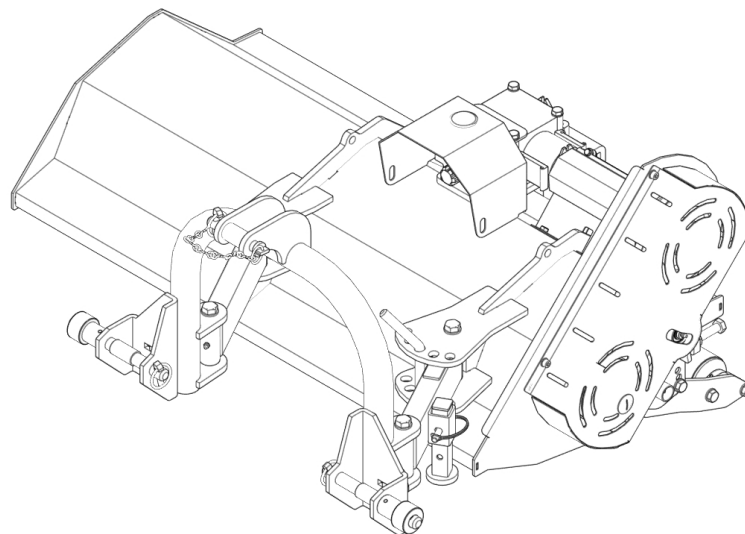

Quick Hitch Attack

7. REAR ROLLER EXTENSION ASSEMBLY

To install the rear roller extension, proceed as follows:

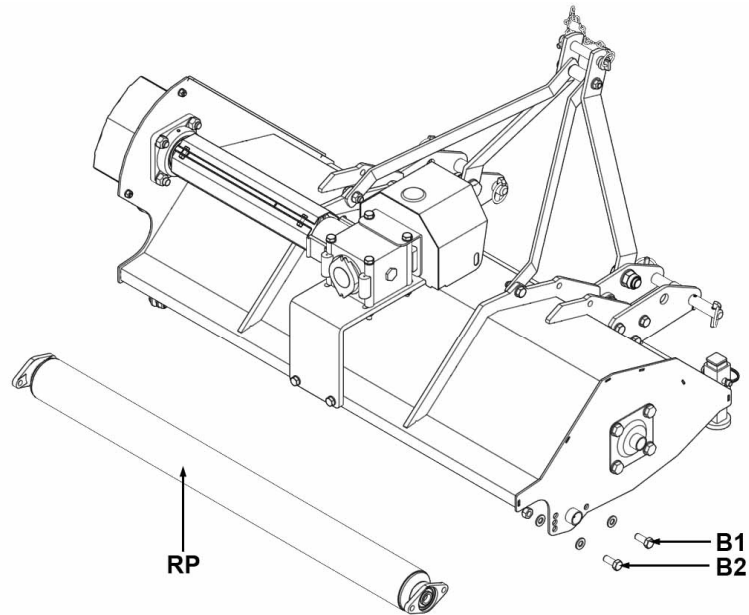

1. Unscrew the bolts "B1" and "B2" on both sides of the machine, then pull out the rear roller "RP".

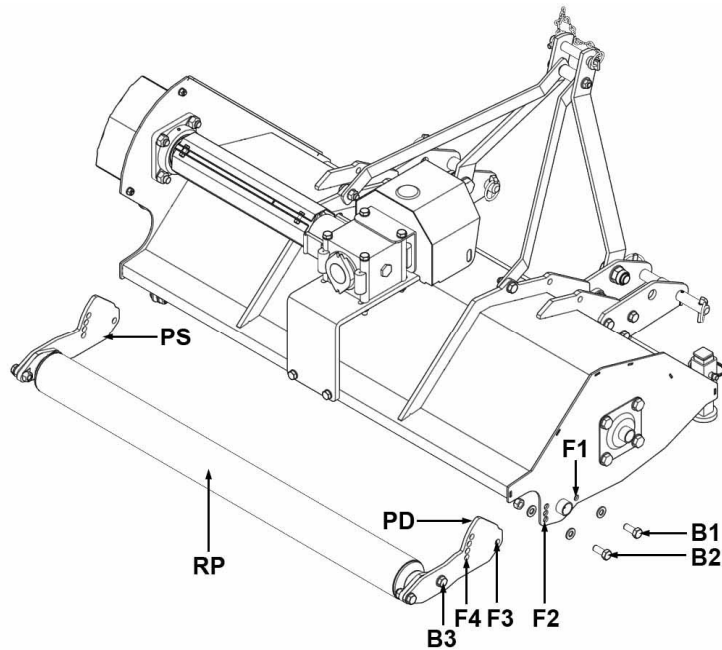

1. Fit the left extension "PS" and the right extension "PD" to the roller supports using the bolts "B3" supplied with the kit.
2. Insert the extensions "PS" and "PD" inside the machine by matching the holes "F1" of the sides with the holes "F3" of the extensions, insert the bolts "B1" without tightening the nuts.
3. Choose the cutting height by matching the holes "F2" of the sides with one of the holes "F4" of the extensions, insert the bolts "B2". Make sure the right and left extensions are adjusted equally, tighten the nuts "B1" and "B2".

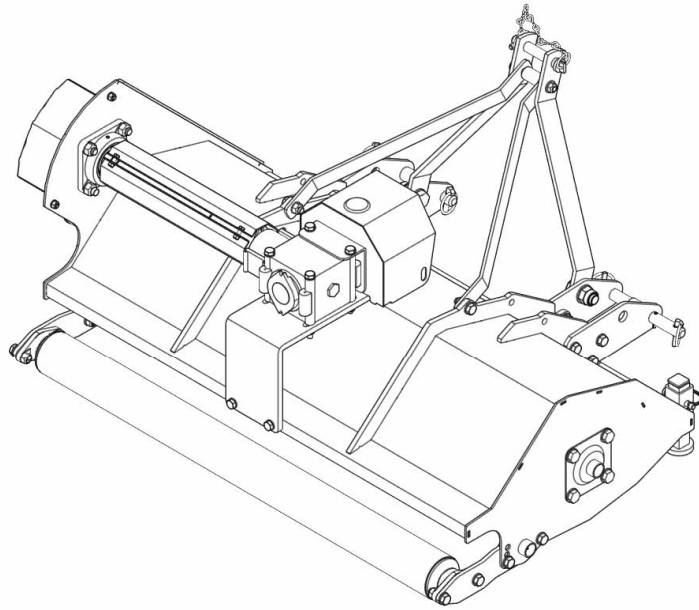

PROBLEMS SOLVING

| TROUBLES | CAUSES AND SOLUTIONS |
|-------------------------------------|--|
| Abnormal vibrations | <ul style="list-style-type: none"> -Not balanced rotor – Enquire a dealer. -Loss of one or more tools – Replace. -Damaged bearings – Replace. |
| Uneven or unsatisfactory cut | <ul style="list-style-type: none"> -Damaged tools – Replace. -Tools choice not good – Change with another type. |

TRANSPORT

Except when working, moving the machine takes place when the machine is standing still and the transmission is disconnected.

<Important>: keep speed low avoiding holes and ground roughness.

<Important>: Before begin the movements always make sure that the safety hooks be in position.

<Note when on the road, obey existing traffic laws. Exhibit the signal signs on the rear ends. Respect any local laws there may be.

STORAGE

Store the machine in a dry place that isn't dusty.

INFORMATION ON DEMOLITION



At the end of its working life, the machine must be sent to be demolished and that can only be done by an authorized authority, in accordance with the national laws in force for the environment. Therefore it is necessary to get information from the qualified local authorities on the procedure to follow. The machine is mainly composed of: iron materials and paints.

WARRANTY

The machine is covered by the manufacturer warranty for a period of 24 months.

The warranty is not applicable when:

- a) The maintenance work has not been done correctly.
- b) The machine has been used out of its own service.
- c) The machine has been transformed or modified without the manufacturer's written authorization.

WORK AND MAINTENANCE SHEET

Every user should register on this sheet the facts about the life of the machine (both work and maintenance), so as to attest its conditions.

| DATE | HOURS | MAINTENANCE | NOTE | OPERATOR |
|-------------|--------------|--------------------|-------------|-----------------|
| | | | | |
| | | | | |
| | | | | |
| | | | | |
| | | | | |
| | | | | |
| | | | | |
| | | | | |
| | | | | |
| | | | | |
| | | | | |
| | | | | |
| | | | | |
| | | | | |
| | | | | |
| | | | | |
| | | | | |
| | | | | |
| | | | | |
| | | | | |
| | | | | |
| | | | | |
| | | | | |
| | | | | |
| | | | | |
| | | | | |
| | | | | |
| | | | | |
| | | | | |
| | | | | |
| | | | | |
| | | | | |
| | | | | |
| | | | | |

INDEX

| | |
|---|-----------|
| PREFACE | 2 |
| DESCRIPTION | 3 |
| FUNCTION OF USE..... | 3 |
| PERFORMANCES..... | 3 |
| PERFORMANCES LIMIT | 3 |
| STANDARD EQUIPMENTS..... | 3 |
| VARIANTS & OPTIONS | 3 |
| TECHNICAL SPECIFICATIONS | 4 |
| SAFETY INFORMATIONS | 5 |
| GENERAL PRESCRIPTIONS..... | 5 |
| SAFETY RESTRICTIONS..... | 5 |
| RUNNING IN..... | 5 |
| SAFETY SIGNS ON THE MACHINE | 6 |
| CARDAN SHAFT LENGTH CHECKING | 7 |
| INSTRUCTIONS FOR USE | 9 |
| 1. BEFORE BEGINNING WORK..... | 9 |
| 2. TO BEGINNING WORK..... | 9 |
| 3. AT THE END OF CUTTING OPERATION | 9 |
| MAINTENANCE INSTRUCTIONS | 10 |
| DIAGRAM "A" SCHEDULED MAINTENANCE..... | 10 |
| 1. GREASING | 11 |
| 2. OIL CHECK - OIL REPLACEMENT IN ALUMINUM GEAR BOX | 11 |
| 3. OIL CHECK - OIL REPLACEMENT IN IRON CASTING GEAR BOX | 12 |
| 4. TOOLS REPLACEMENT | 13 |
| 5. BELTS ADJUSTING AND REPLACEMENT | 13 |
| 6. QUICK HITCH KIT ASSEMBLY | 14 |
| 7. REAR ROLLER EXTENSION ASSEMBLY | 16 |
| PROBLEMS SOLVING | 17 |
| TRANSPORT | 18 |
| STORAGE | 18 |
| INFORMATION ON DEMOLITION | 18 |
| WARRANTY | 18 |
| WORK AND MAINTENANCE SHEET | 19 |